

OLD-FASHIONED

FIREPLACES

ELLIOTT'S WEST HOWE POTTERY (DORSET) LTD, KINSON, N. BOURNEMOUTH

Working details of any of the
designs shown here will be
supplied on request at a nominal
charge of 2s. 6d.

SUGGESTIONS
for
BRICK AND TILE
FIREPLACES

CHIMNEYS

PERGOLA
COLUMNS

GARDEN
ORNAMENTS

By ANTIQUE SECTION of
ELLIOTT'S WEST HOWE
POTTERY (DORSET) LTD.
KINSON
NR BOURNEMOUTH



FIREBACKS AND BOTTOMS
CAN BE SUPPLIED AS AN
EXTRA IF REQUIRED

PRICES QUOTED ARE
SUBJECT TO FLUCTU-
ATION WITHOUT NOTICE

PRICES QUOTED ARE
FOR POOLE STATION

PACKAGES ARE CHARGED
FOR BUT ARE RETURNABLE

Introduction

THIS BOOKLET is issued in the belief that it may be of assistance to Architects and Builders as well as to the Private Individual, primarily in connection with the use of

ELLIOTT'S
SMALL ANTIQUE HAND
MADE BRICKS AND TILES

for Old English Fireplaces.

A number of designs of fireplaces are shown as suggestions and prices quoted, but a special feature of our works in the past has been the carrying out of Architects' own designs, and we shall always be pleased to quote estimates for this work promptly.

All enquiries, etc., to be sent direct
to
ELLIOTT'S
WEST HOWE POTTERY
(DORSET) LTD.

KINSON
NEAR BOURNEMOUTH
Telephone - Longham 15
Telegrams :
Elliotts, Kinson, Bournemouth



An Old Kiln

FIREBACKS AND BOTTOMS
CAN BE SUPPLIED AS AN
EXTRA IF REQUIRED

PRICES QUOTED ARE
SUBJECT TO FLUCTU-
ATION WITHOUT NOTICE

PRICES QUOTED ARE
FOR POOLE STATION

PACKAGES ARE CHARGED
FOR BUT ARE RETURNABLE

Introduction

THIS BOOKLET is issued in the belief that it may be of assistance to Architects and Builders as well as to the Private Individual, primarily in connection with the use of

ELLIOTT'S SMALL ANTIQUE HAND MADE BRICKS AND TILES

for Old English Fireplaces.

A number of designs of fireplaces are shown as suggestions and prices quoted, but a special feature of our works in the past has been the carrying out of Architects' own designs, and we shall always be pleased to quote estimates for this work promptly.

All enquiries, etc., to be sent direct
to
ELLIOTT'S
WEST HOWE POTTERY
(DORSET) LTD.

KINSON
NEAR BOURNEMOUTH
Telephone - Longham 15
Telegrams :
Elliotts, Kinson, Bournemouth



An Old Kiln

10-11314-B2943

A few designs of garden ornament are included to indicate the variety of uses of our bricks, and this class of work to special designs will receive our prompt attention.



Clay Pugging by the Old Method

THERE is enclosed with this Booklet a sheet of diagrams showing a number of the different bricks we make, giving their measurements and a few suggestions as to their uses. Special attention is drawn to our

OCTAGON BRICKS

Nos. C, C₁, C₂, D, D₁, E and F, which have a multitude of uses, some of which are shown on the pages of this booklet. (Sketch Nos. 5, 7, 13, 18, 19).

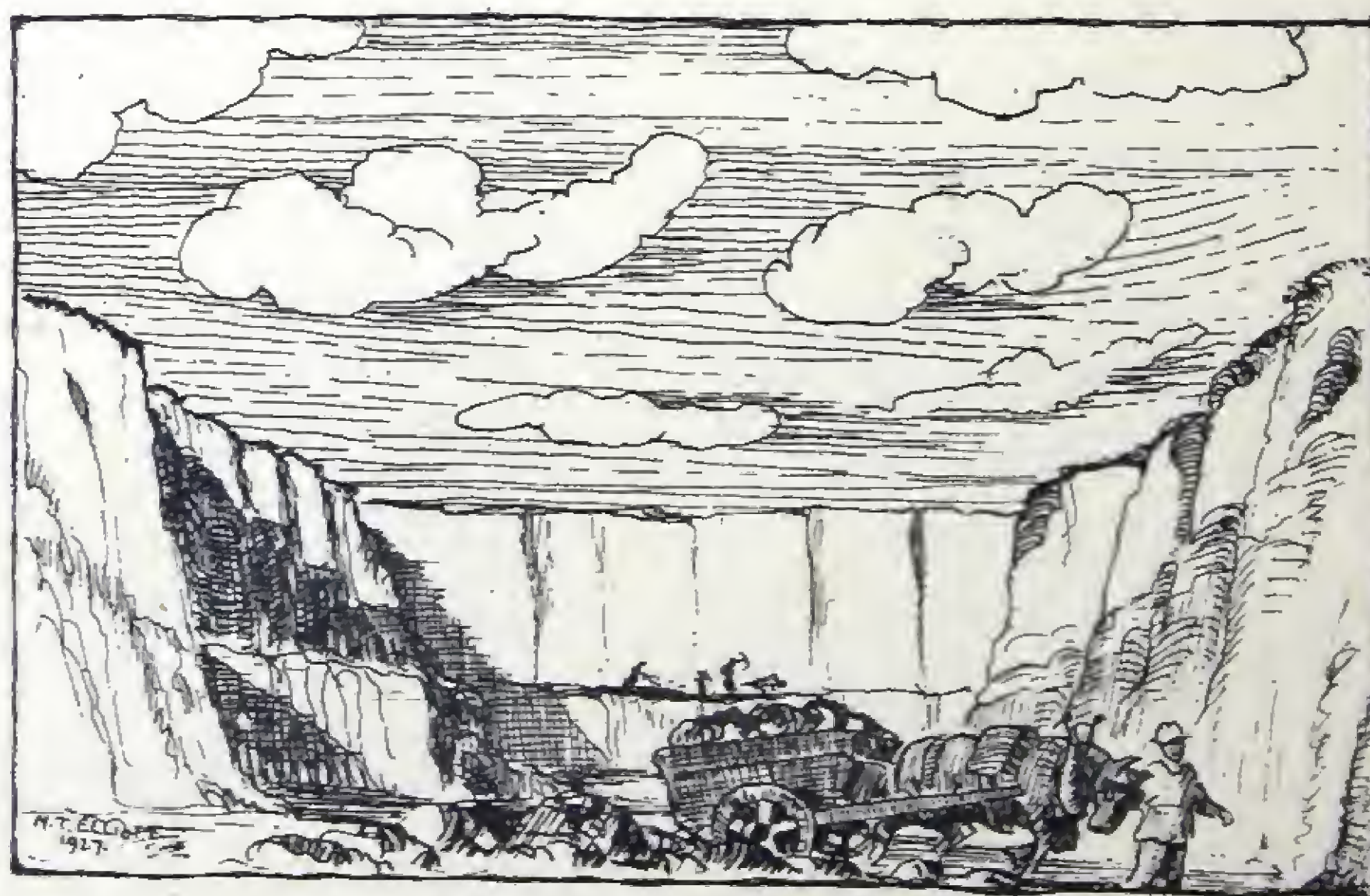

The Old-time Clay Pit



General View of Old Style Brick Works

IN conclusion, we will be pleased to show any client over our works, where the making of these "Antique Bricks" and also the modern and up-to-date methods of the manufacture of "Sand and Lime Bricks" and "Stoneware Drainpipes and Fittings" can be seen.

A postcard will ensure your being conducted by Mr. Elliott, personally.



Sketch Design, No. 1

THIS DESIGN IS MADE UP AS FOLLOWS:

CURB	BRICKS	M3
HEARTH	"	"
MAIN BRICKWORK	"	"
MANTEL SHELF TOP	"	K & K1
ARCH OVER MANTEL SHELF	TILES	N1

Price £4 10s. od.



Sketch Design, No. 2

THIS DESIGN IS MADE UP AS FOLLOWS :

HEARTH	TILES	O
CURB	BRICKS	M3
JAMBS	"	M3
SPANDRIL	"	M3 LAID FLAT
ARCH	TILES	N1
FILLING	"	N1

Price for Bricks only :
£2 10s. od.



Sketch Design, No. 3

THIS DESIGN IS MADE UP AS FOLLOWS:

- CURB BRICKS M3
- HEARTH TILES O
- PLINTH BRICKS M3 AND MOULDED BRICKS I AND J
- ARCH TILES N1
- MAIN BRICKWORK BRICKS M3
- SPLAY SIDES " "
- MANTEL SHELF..... " " AND MOULDED BRICKS K AND L
- CORNICE..... " " " "

Price £10 0s. 0d.

This design is copyright

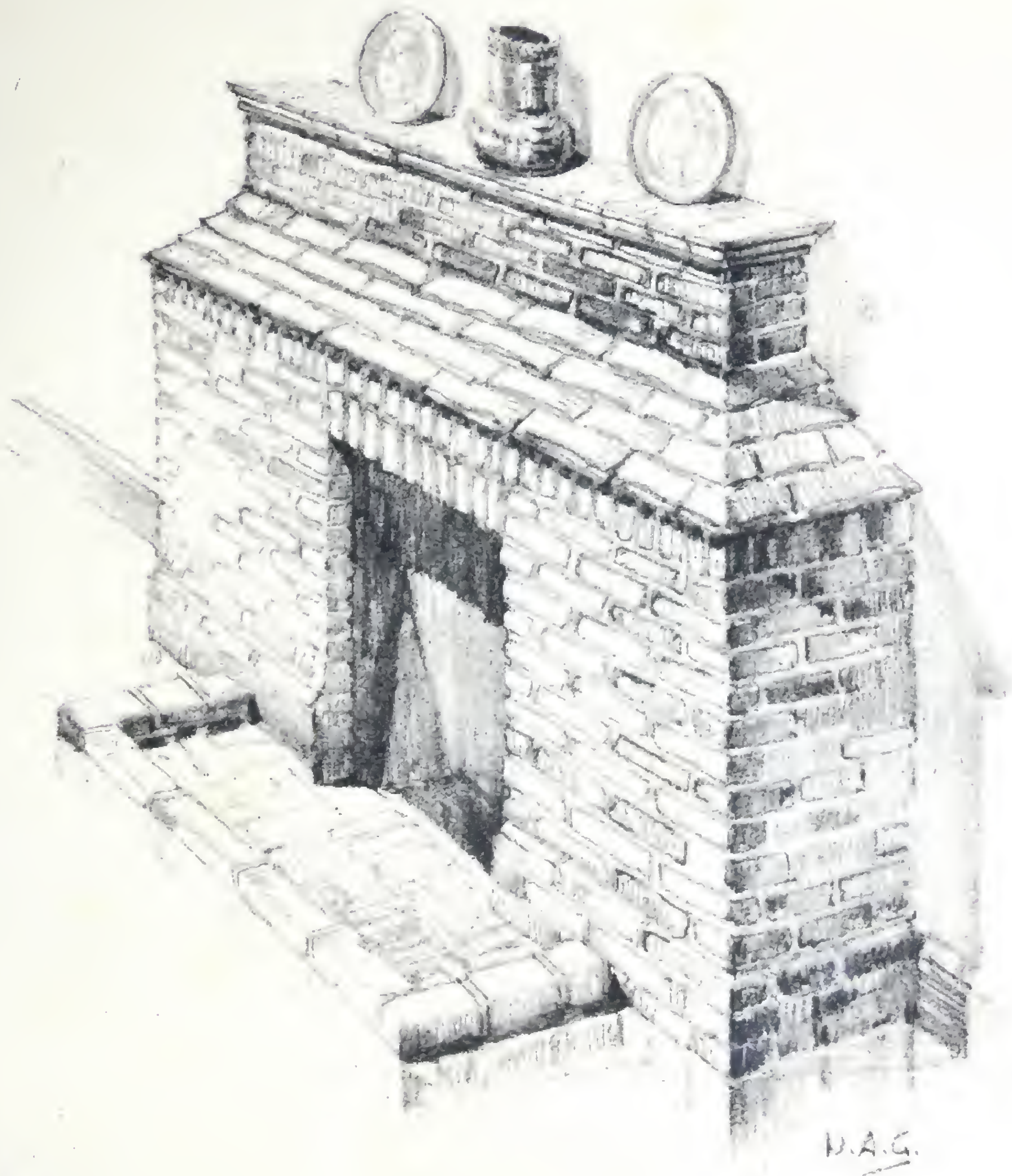

Sketch Design, No. 4

THIS DESIGN IS MADE UP AS FOLLOWS :

CURB	BRICKS M3
HEARTH	" "
PLINTH	" "
MAIN BRICKWORK	" "
SLOPE	TILES N-N1 OR ROOFING TILES
SHELF TOP	" K1 AND L

Price £6 os. od.



Sketch Design, No. 5

THIS DESIGN IS MADE UP AS FOLLOWS :

CURB	BRICKS	M3
HEARTH	"	"
PLINTH	"	D1 & C2
SIDE PIERS	"	C & C2
ARCHES & BRICKWORK BETWEEN	"	M3
SHELF	TILES	N1

Price £5 os. od.

Page Ten

This design is copyright



Sketch Design, No. 6

THIS DESIGN IS MADE UP AS FOLLOWS :

CURB	BRICKS P1 AND Q1
HEARTH	" M3
HOBBS	" "
BRICKWORK	" "
ARCH.....	TILES N1
INNER SURROUND	" " CORNER TILES O
OUTER	" " K AND L LAID FLAT

Price £4 10s. od.
Mantel not included



Sketch Design, No. 7

THIS DESIGN IS MADE UP AS FOLLOWS :

CURB	BRICKS P1 AND Q1
HEARTH	" M3
MAIN BRICKWORK AND PLINTH	" "
ARCH	" K LAID FLAT AND TILES N1
SHELVES	" K AND L
SPLAY SIDES	" C
CORNICE.....	" K AND L

Price £12 10s. od.

Page
Twelve

This design is copyright



Sketch Design, No. 8

THIS DESIGN IS MADE UP AS FOLLOWS :

CURB AND HEARTH	BRICKS M3
HOBS	" "
PLINTH	" " AND TILES N1
MAIN BRICKWORK	" "
ARCH	TILES N1
MANTEL SHELF.....	" "
TOP OF MANTEL SHELF & SIDE SLOPES ...	ROOFING TILES
CORNICE.....	BRICKS K AND L

Price £11 os. od.

Page
Thirteen

This design is copyright

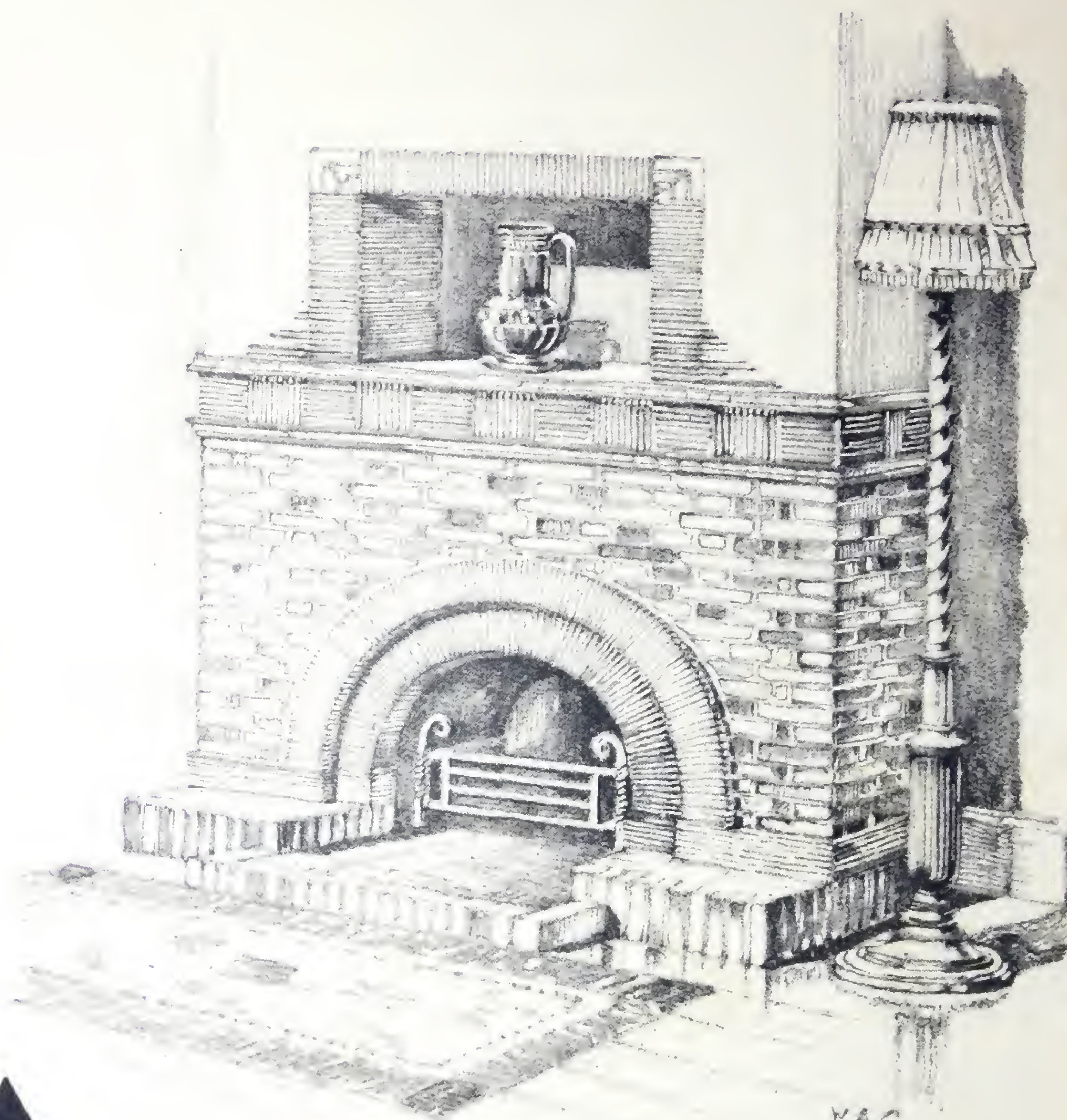

Sketch Design. No. 9

THIS DESIGN IS MADE UP AS FOLLOWS

- CURB BRICKS M2
- HEARTH TILES O
- HOBBS BRICKS M2
- PLINTH AND ARCH..... TILES N1
- BRICKWORK BRICKS M2
- ORNAMENTAL BAND " K & L & TILES N1
- MANTEL RECESS N1
- SURROUND AND ARCH TILES N1
- CORNERS..... BRICKS G

Price £10 os. od.

Page
Fourteen

This design is copyright

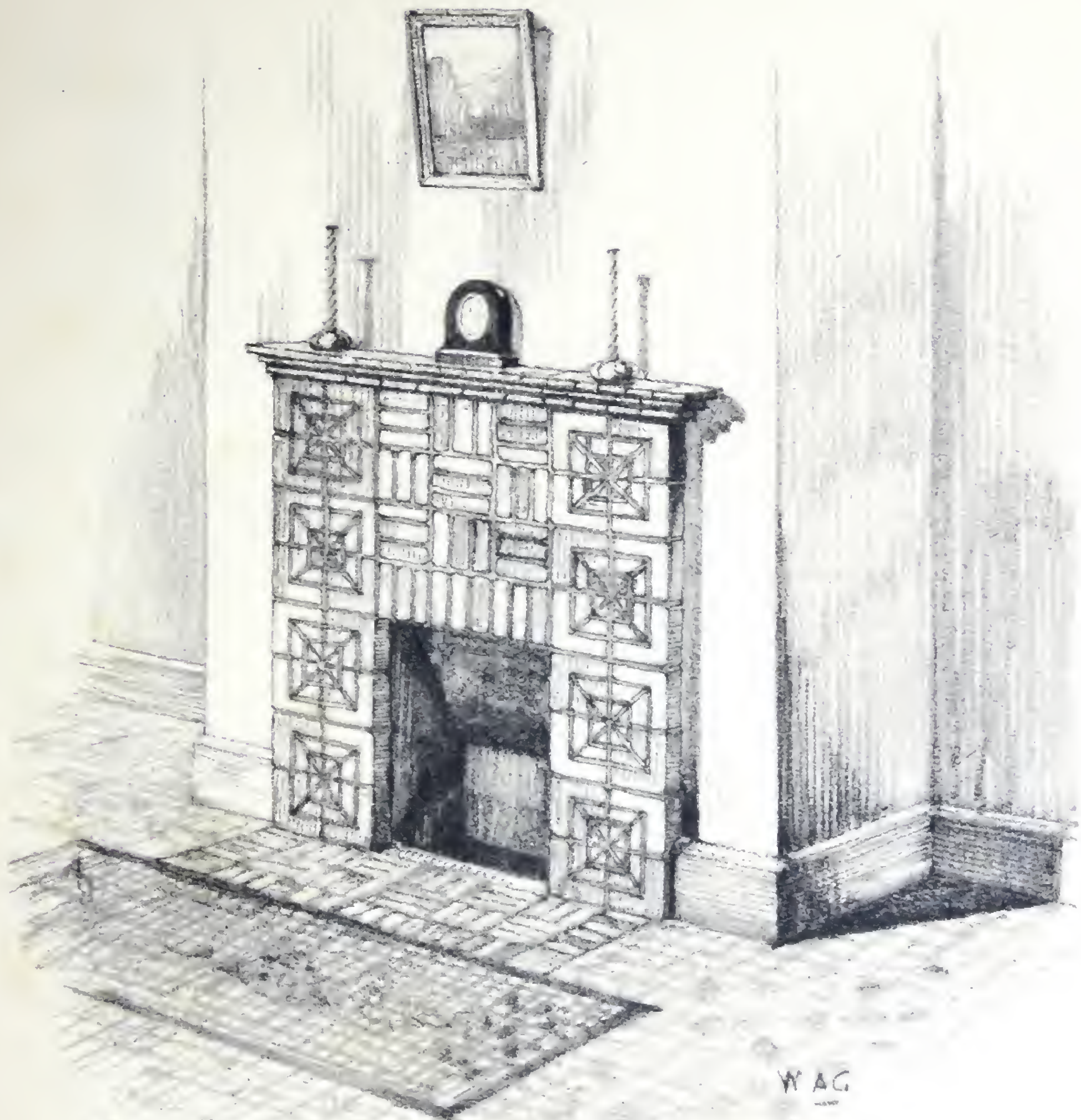

Sketch Design, No. 10

THIS DESIGN IS MADE UP AS FOLLOWS :
 HEARTH BRICKS M3
 SURROUND..... " M3 AND G
 SHELF..... TILES N1

Price £3 10s. od.



Sketch Design, No. 11

THIS DESIGN IS MADE UP AS FOLLOWS:

CURB BRICKS H1 AND B
 HEARTH " M3
 SURROUND .. " M3, M2 C AND TILE O
 SHELF..... TILES N1 AND BRICKS K AND L

Price £3 os. od.

Page
 Sixteen

This design is copyright

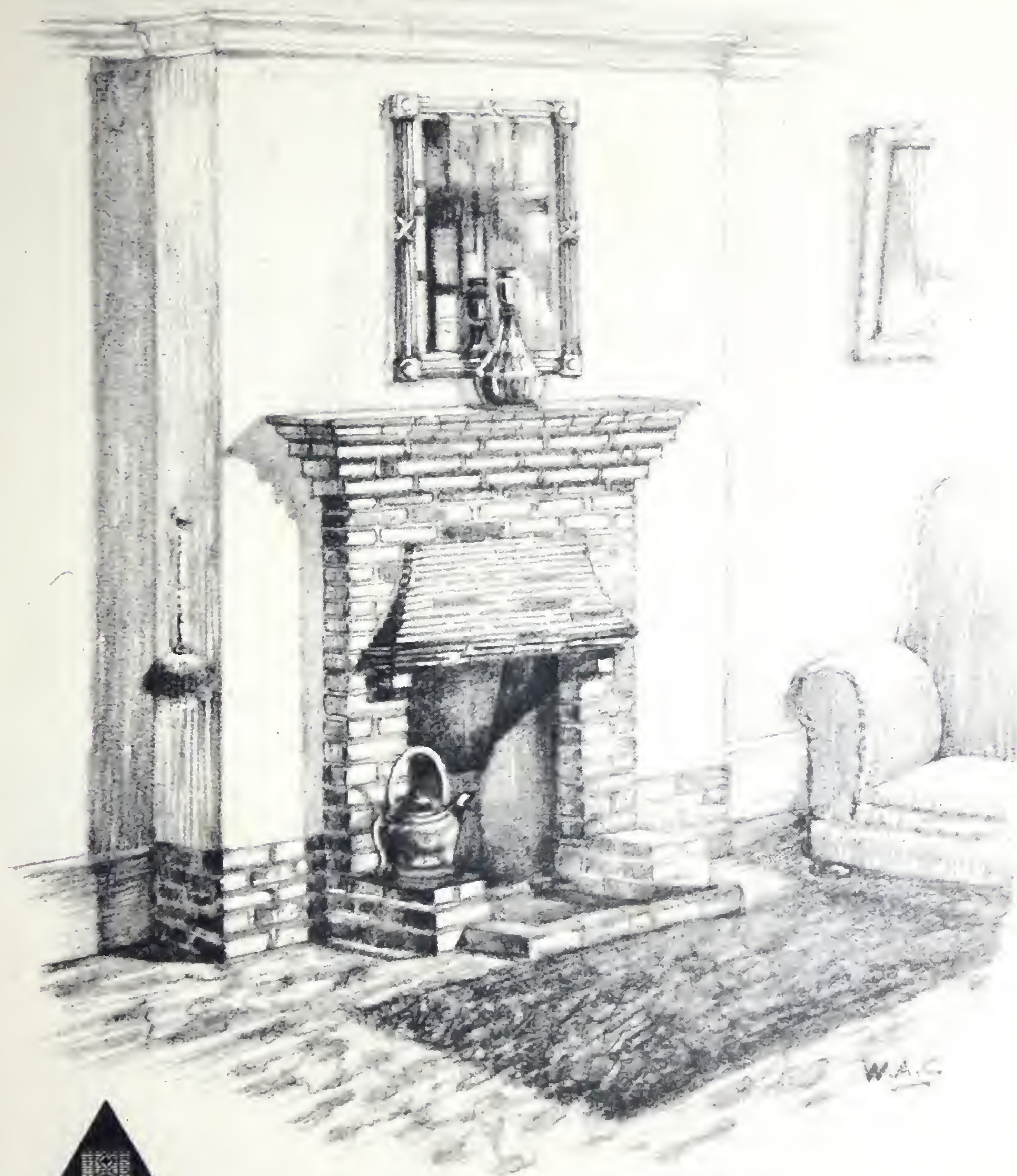

Sketch Design, No. 12

THIS DESIGN IS MADE UP AS FOLLOWS:

- CURB BRICKS M3
- HEARTH " "
- HOBS " "
- MAIN BRICKWORK " "
- CANOPY TILES N1
- SHELF TOP BRICKS K AND L

Price £3 10s. od.

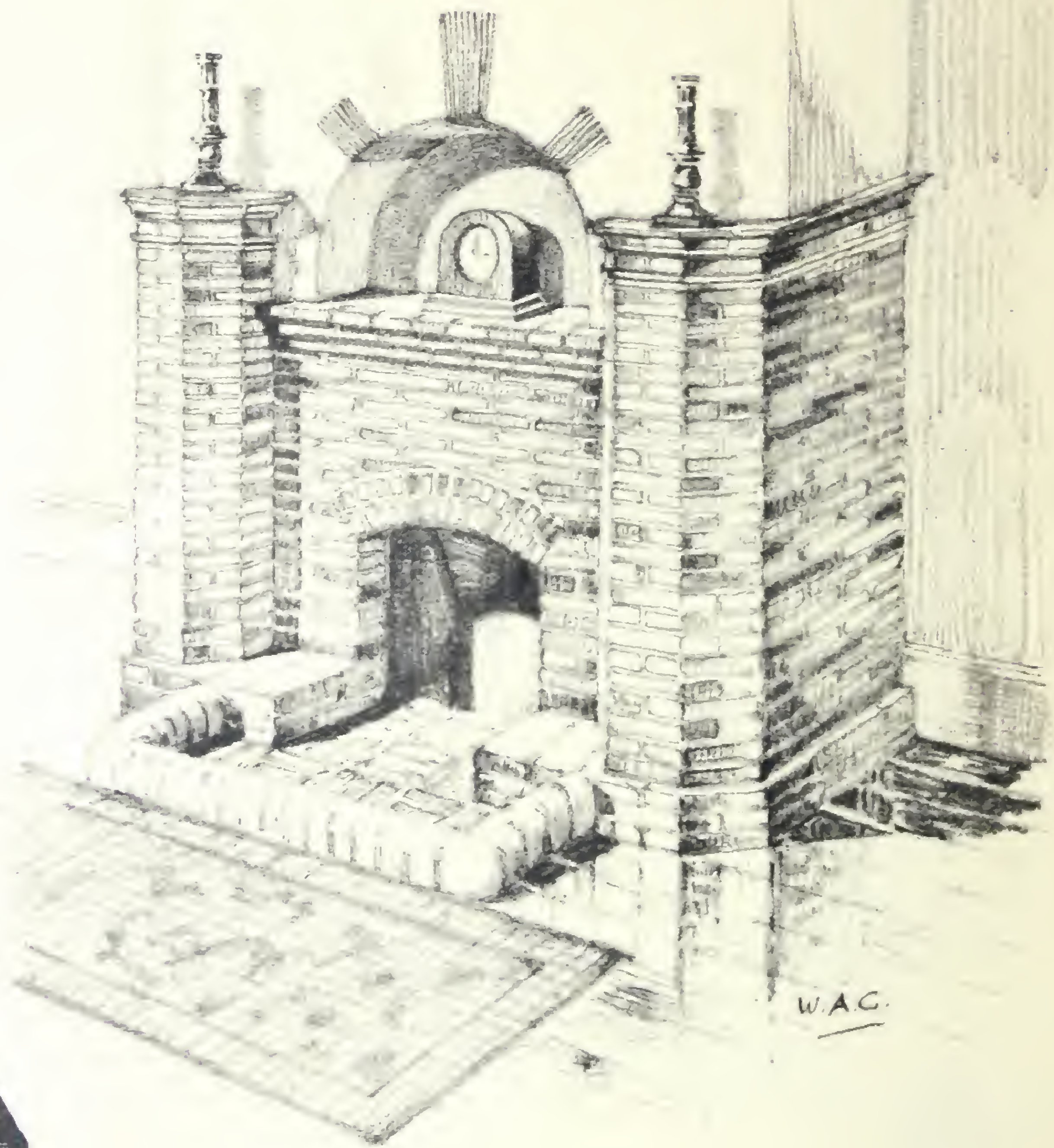

Sketch Design, No. 13

THIS DESIGN IS MADE UP AS FOLLOWS :

CURB	BRICKS	P1 AND Q1
HEARTH	"	M3
HOBS	"	M2
SIDE PIERS	"	C, C1, C2 AND D—D1 FOR PLINTH
NECKING	TILE	N1
CAPS	"	K, L, AND E
CENTRE BRICKWORK	BRICKS	M2
ARCH	"	"
SHELF	TILES	N
TOP ARCH KEY & VOUSOIRS ...	"	N1

Price £9 10s. od.

Page Eighteen

This design is copyright

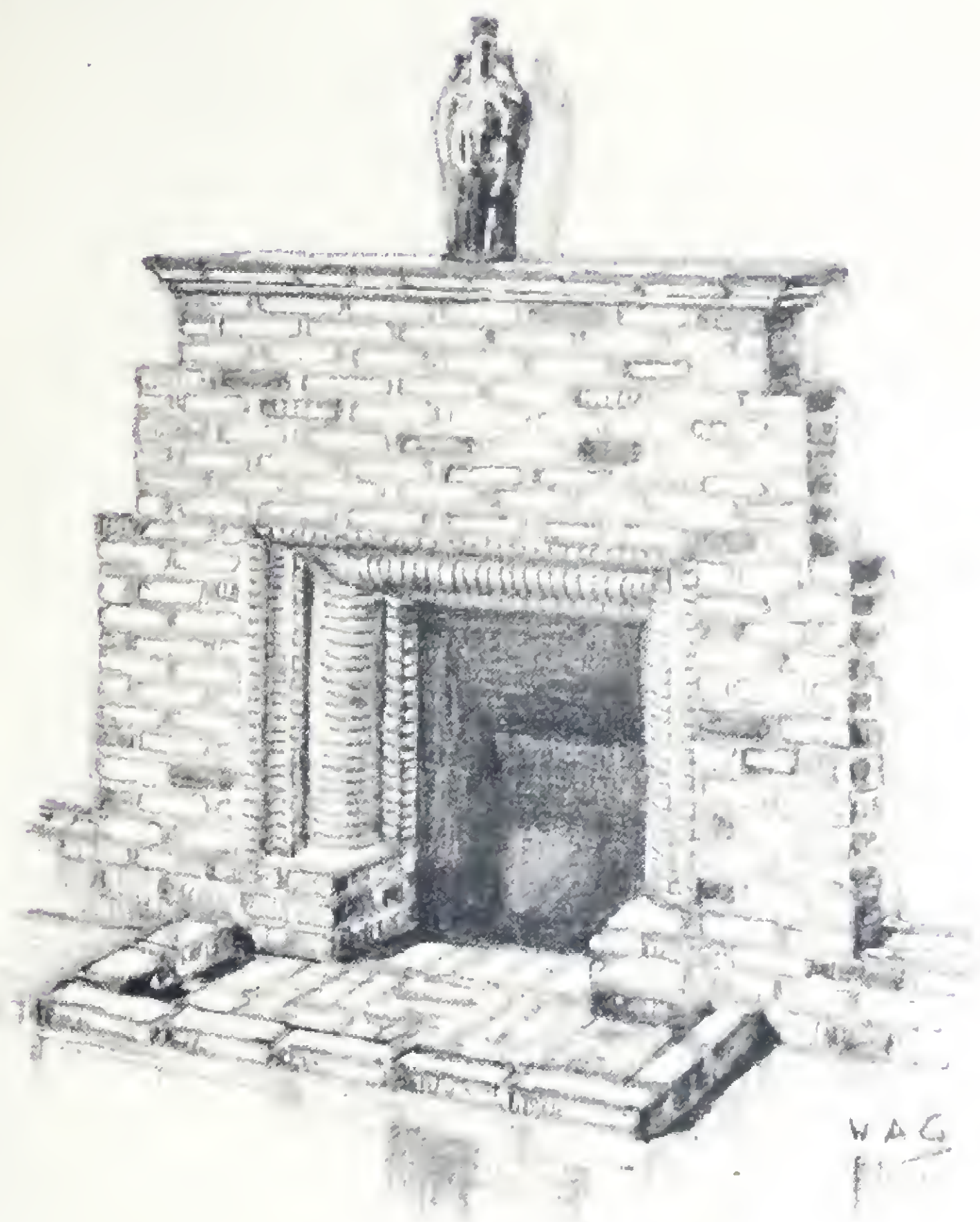

Sketch Design, No. 14

THIS DESIGN IS MADE UP AS FOLLOWS :

- CURB BRICKS M3
- HEARTH " "
- PLINTH " " AND K
- ARCH..... TILES S
- SURROUND..... BRICKS M3
- SHELF..... K AND L

Price £4 os. od.



Sketch Design, No 15

- THIS DESIGN IS MADE UP AS FOLLOWS:
- CURB BRICKS P1 AND Q1
 - HEARTH TILES O
 - PLINTH BRICKS M2 TILES N
 - ARCH..... TILES N AND S
 - RECESS JAMBS ... BRICKS M2
 - SHELF..... " K AND L
 - TOP " M2
 - CORNICE " K AND L

Price £5 10s. od.

This design is copyright



Sketch Design, No. 16

THIS DESIGN IS MADE UP AS FOLLOWS :

- CURB BRICKS P1 AND Q1
- HEARTH TILES O
- SURROUND..... BRICKS M2
- ARCH..... " "
- SHELVES " K AND L

Price £4 10s. 0d.

Page
Twenty-one



Sketch Design. No. 17

THIS DESIGN IS MADE UP AS FOLLOWS :

- PLINTH BRICKS M2 I AND J
- MAIN WALL " M2
- SIDE OPENINGS
- HEAD TILES N1
- SILLS BRICKS K AND L
- COPINGS " M2 ON EDGE K AND I.
- ARCH..... " M2

This design is copyright

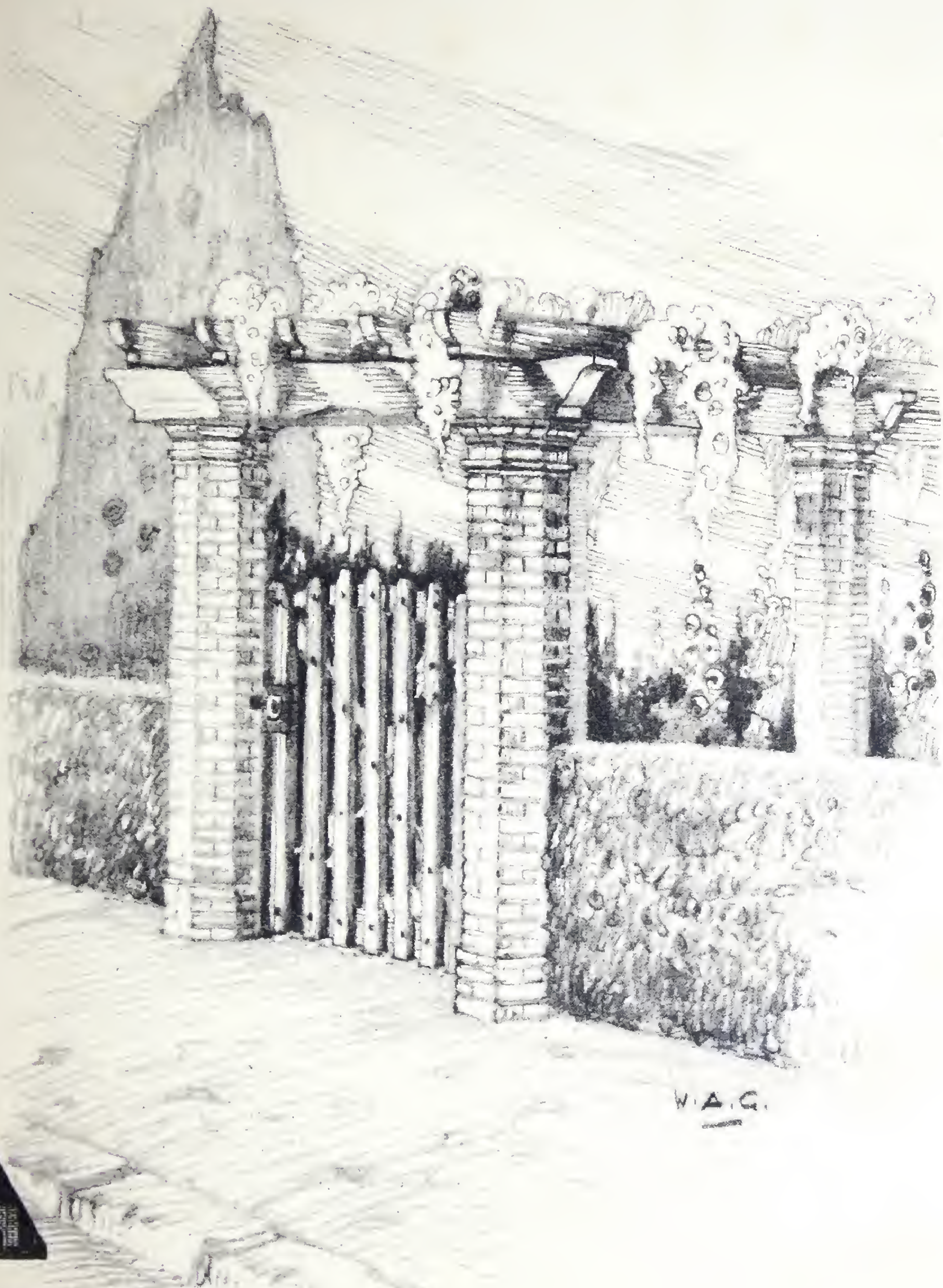

Sketch Design. No. 18

THIS DESIGN IS MADE UP AS FOLLOWS :

- BASE BRICKS D1
- PIER " C
- NECKING TILE N1
- CAP BRICKS E AND K



Sketch Design, No. 19

THIS DESIGN IS MADE UP AS FOLLOWS :

BASE	M2
PLINTH	N OR N1
STACK	D1
NECKING	TILES N AND N1
CAP	BRICKS E AND K

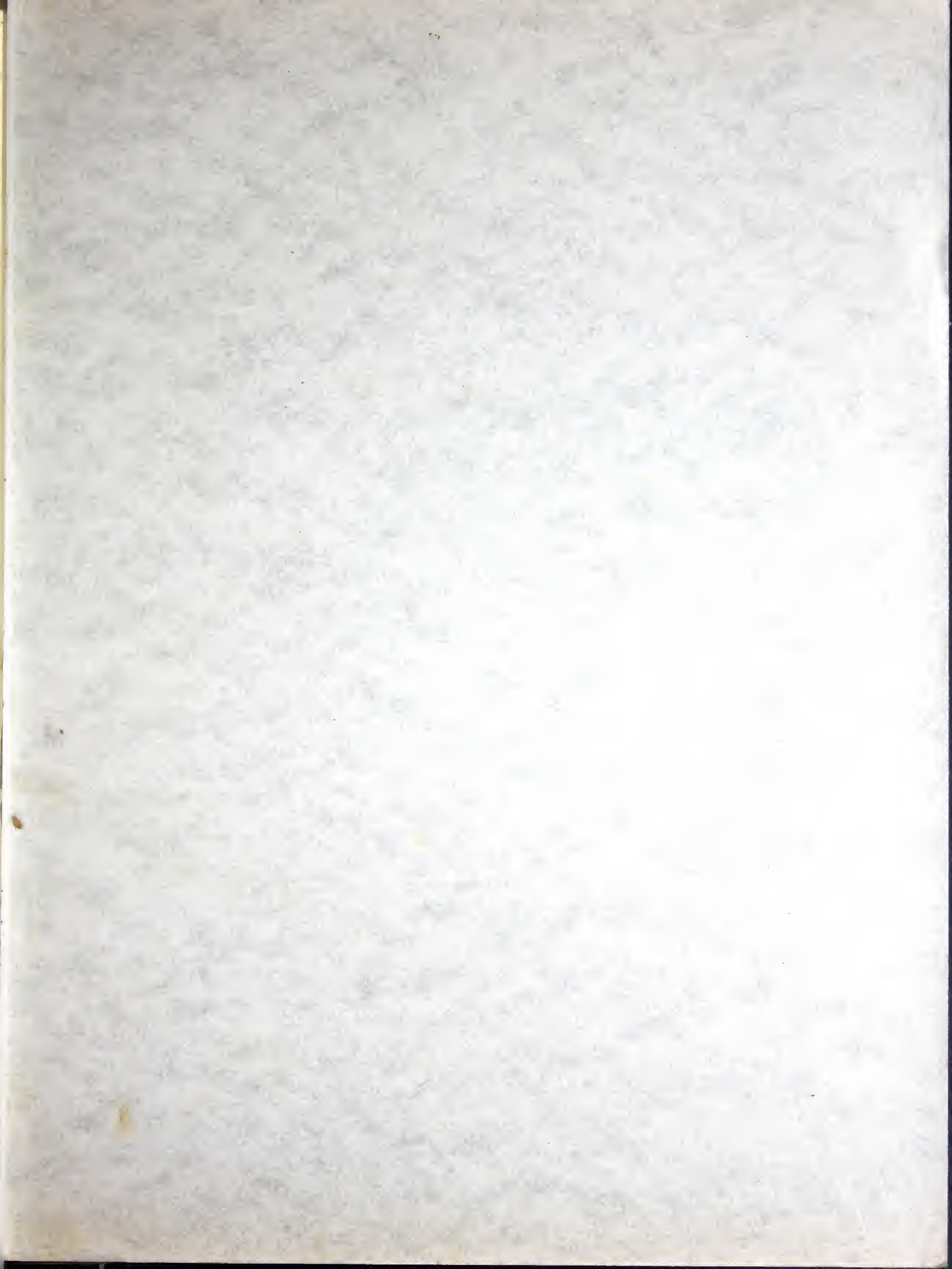

[BLANK PAGE]



CCA

SUPPLEMENTARY LIST SHOWING DIAGRAMS
OF
SANDFACED ANTIQUE BRICKS
AND SPECIALS
for
BRICK FIREPLACES
ETC.

Manufactured by the Antique Section of
ELLIOTT'S WEST HOWE POTTERY (DORSET), LTD.
KINSON,
NR. BOURNEMOUTH

List No. 2

DIAGRAMS OF ELLIOTT'S SMALL ANTIQUE BRICKS

Made by the ANTIQUE SECTION of
ELLIOTT'S WEST HOWE POTTERY (DORSET), LTD., KINSON, NR. BOURNEMOUTH

LIST No. 2

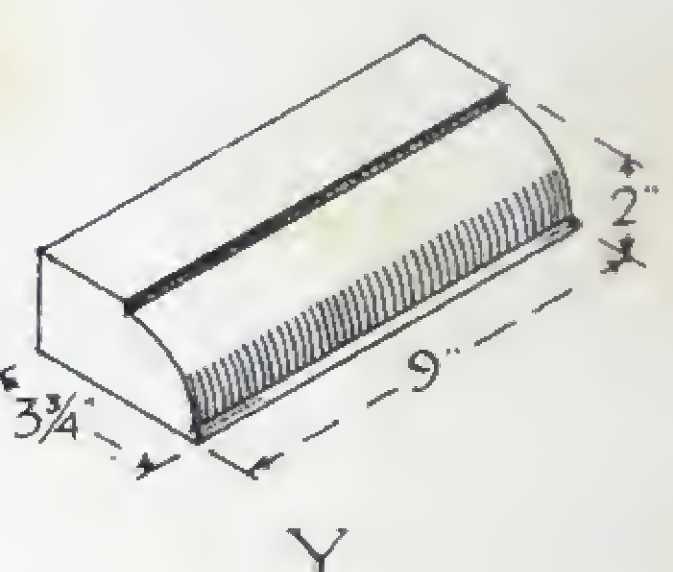
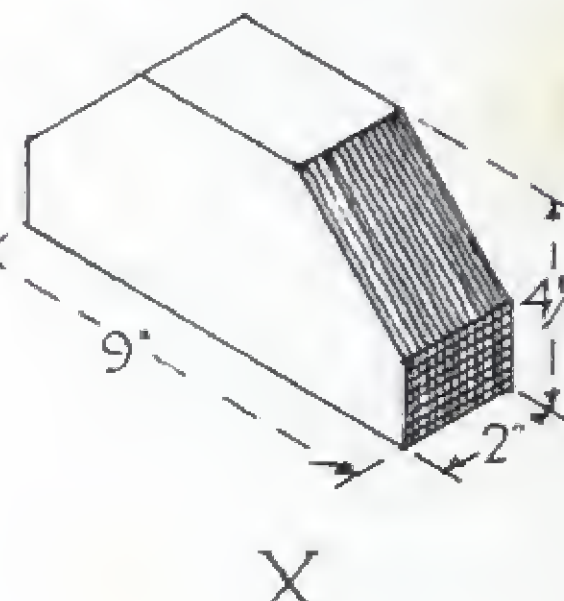
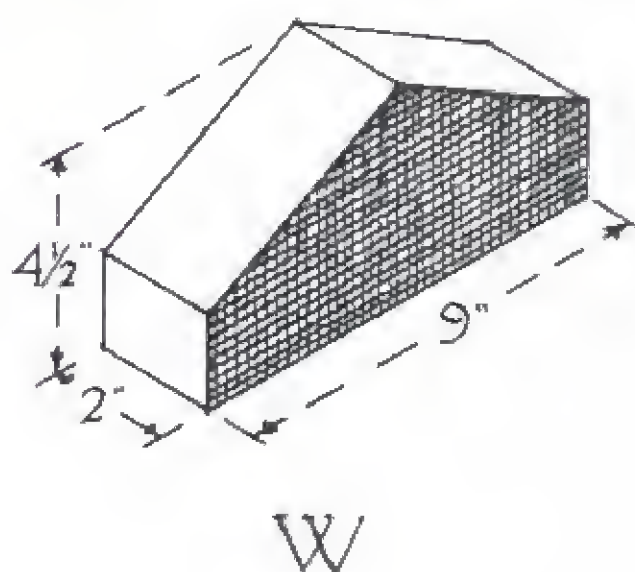
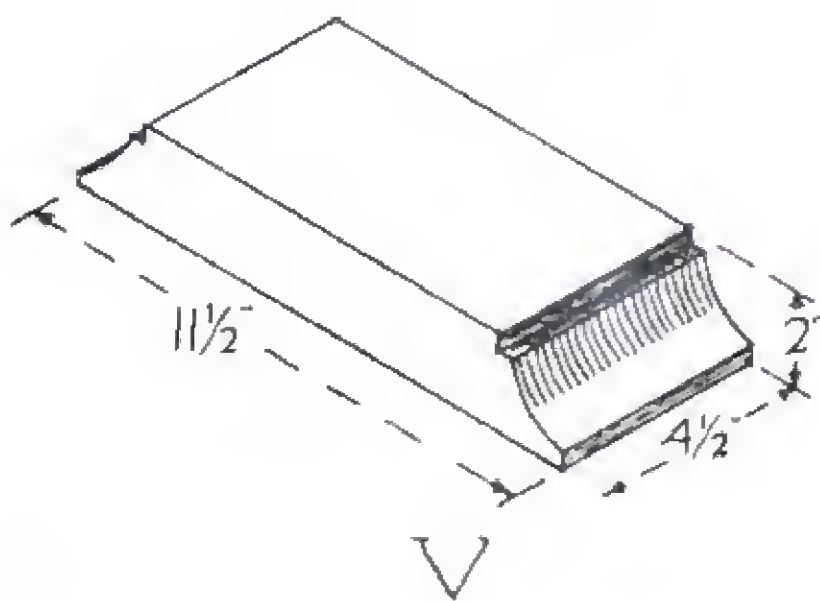
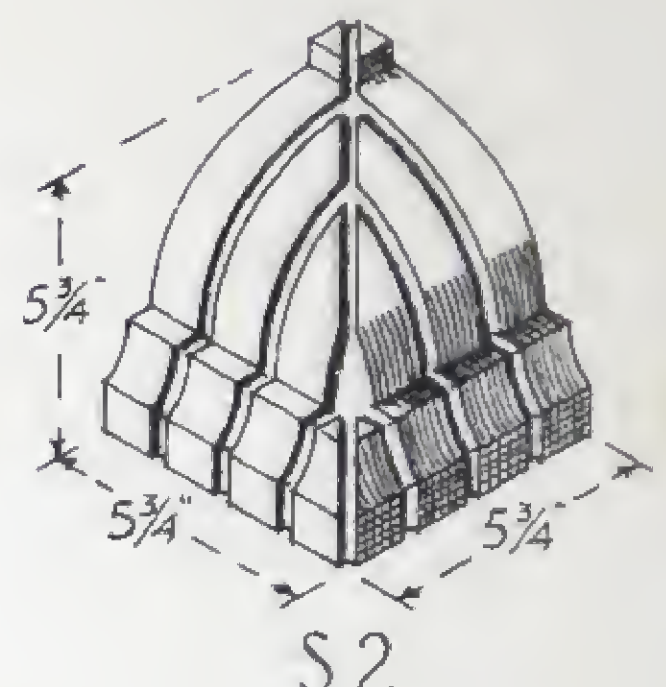
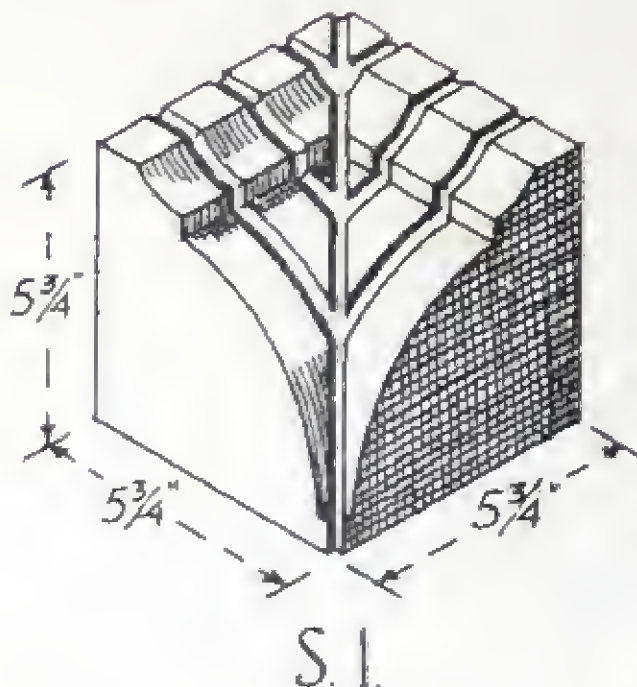
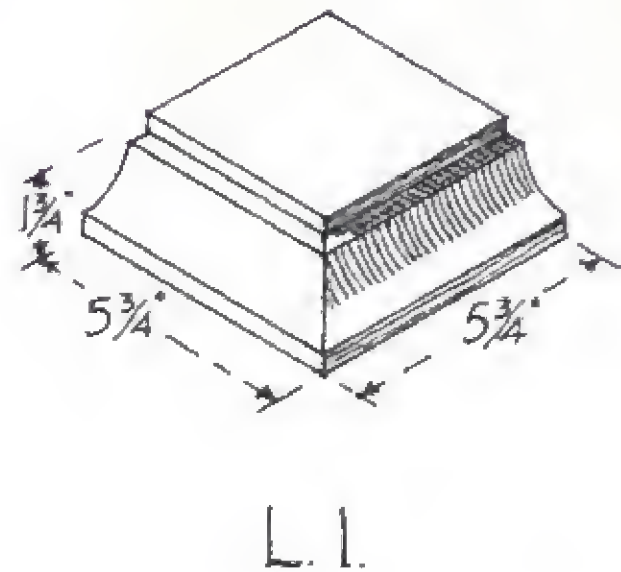
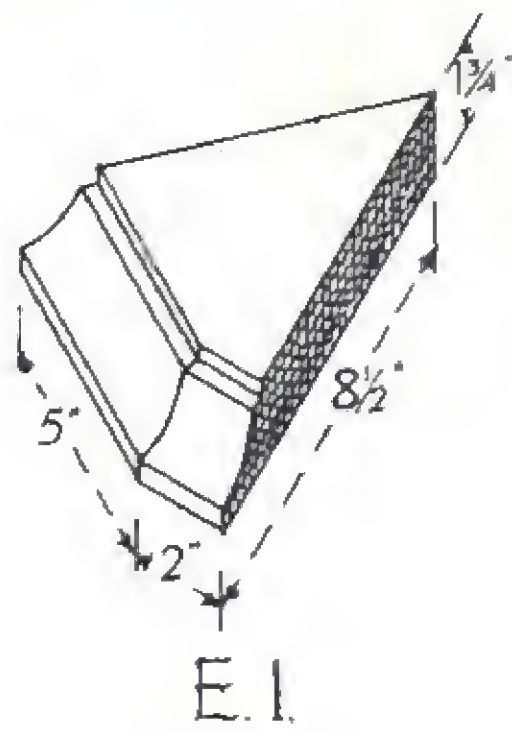
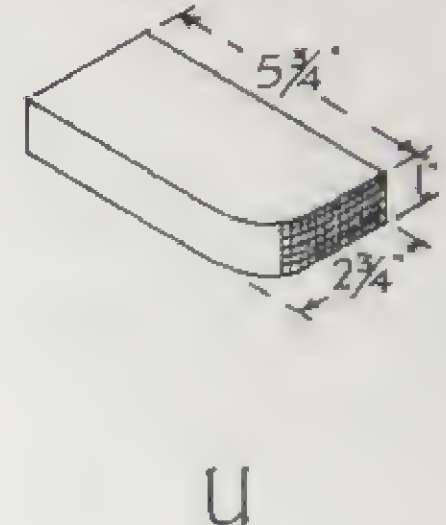
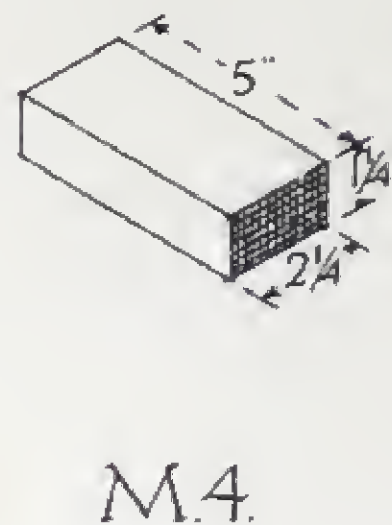
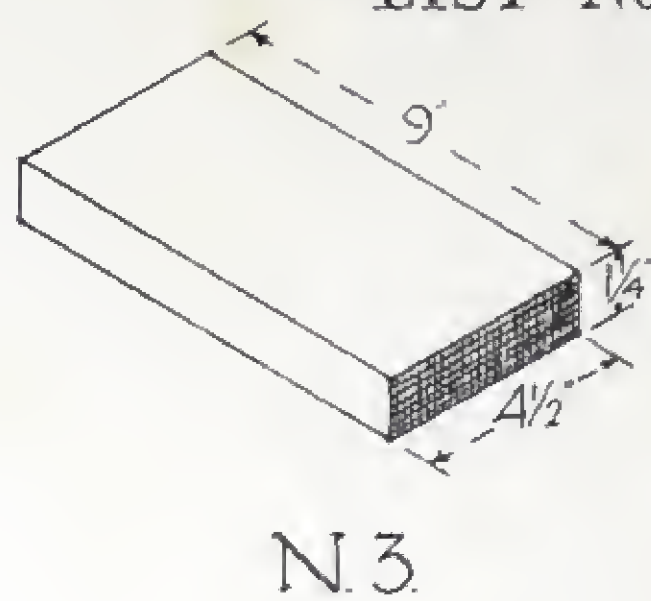
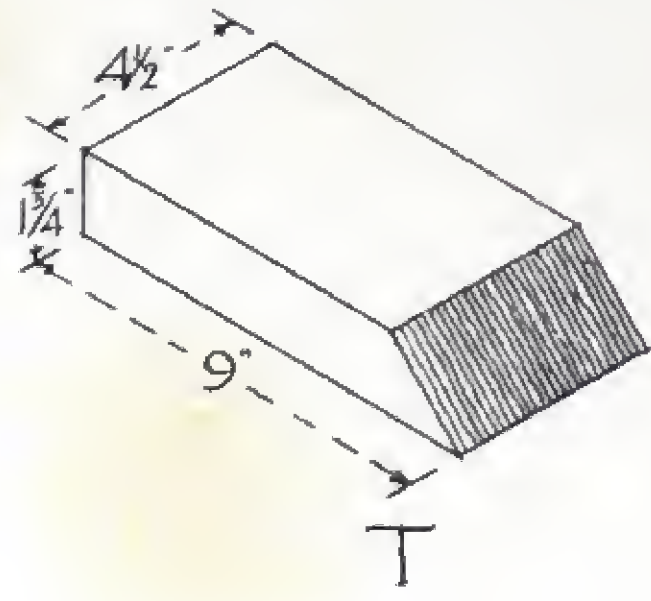

MULLION BRICKS

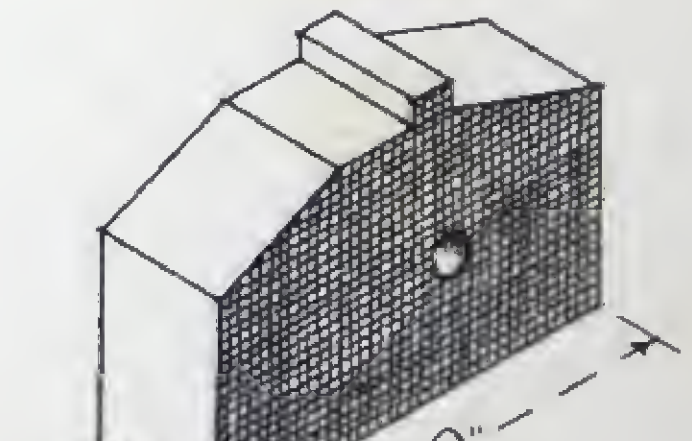
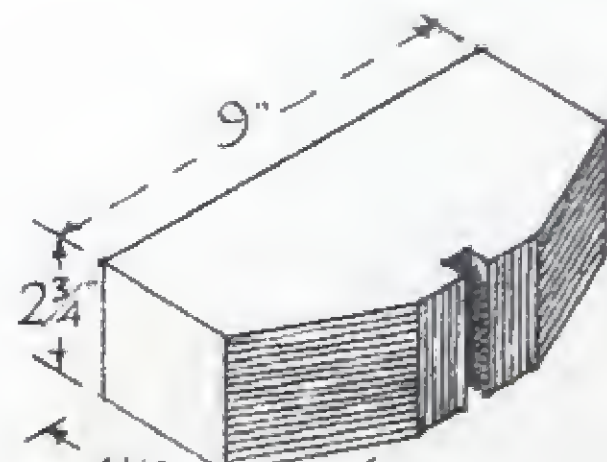
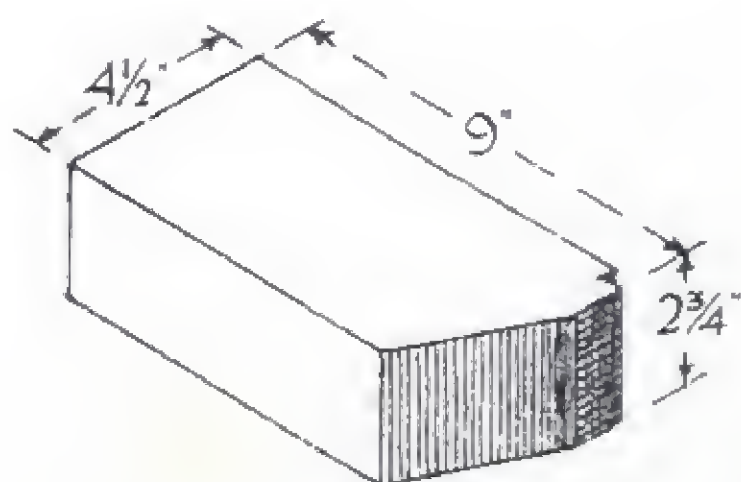
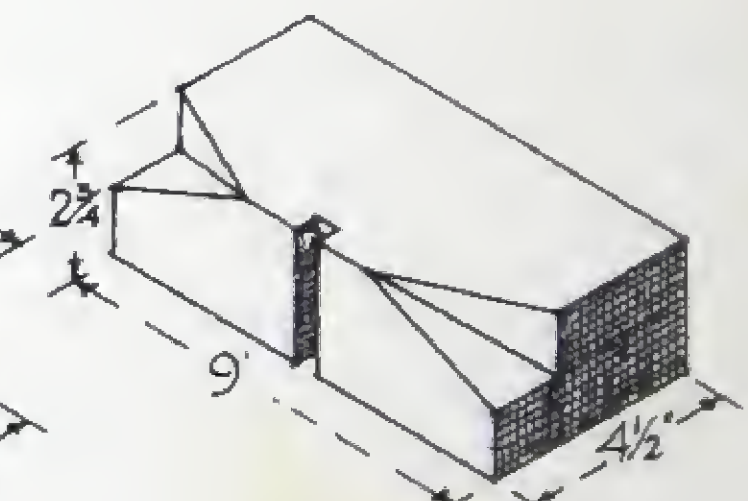
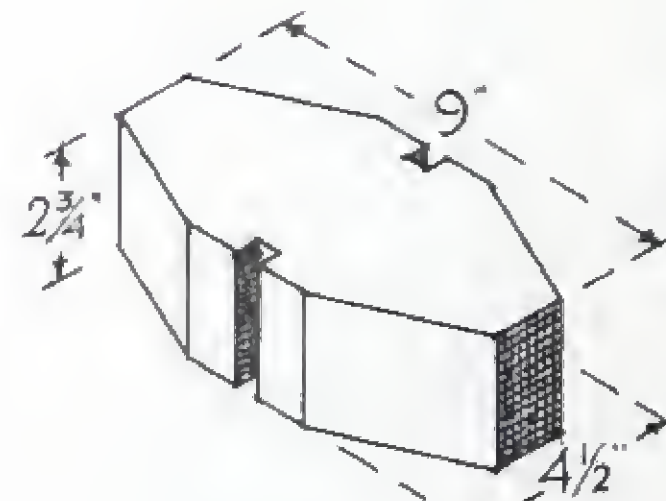
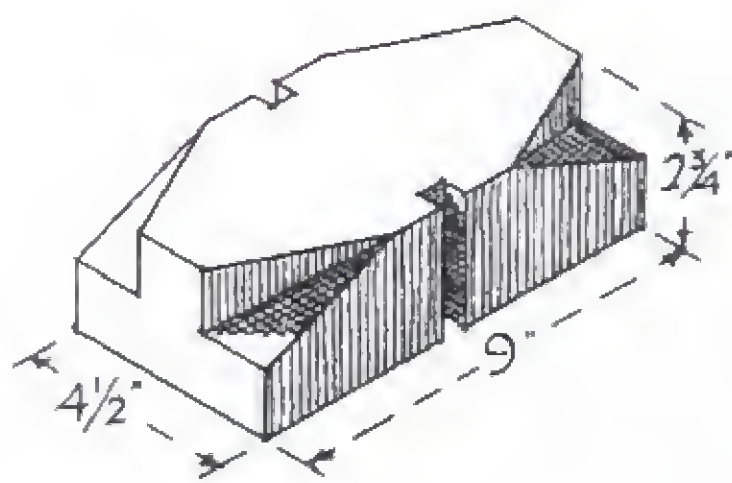

4

5

6

This Sheet is Copyright and the rights are strictly reserved.

DIAGRAMS OF

ICKS



THE
WESTHOWE FIRE

Manufactured by

ELLIOTT'S WEST HOWE POTTERY (DORSET) Ltd.

), LTD.

WEST HOWE

BOURNEMOUTH

Telephone : Longham 15

Telegrams : " Elliott's, Kinson, Bournemouth "

DIAGRAMS

ELLIOTT'S WEST

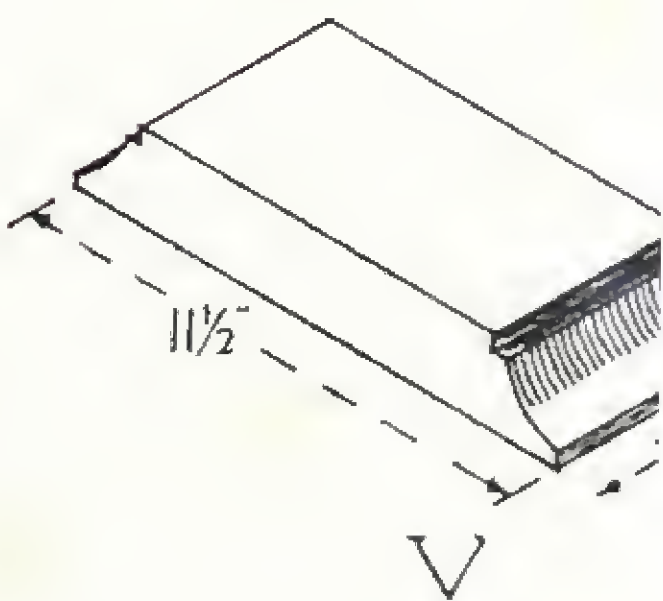
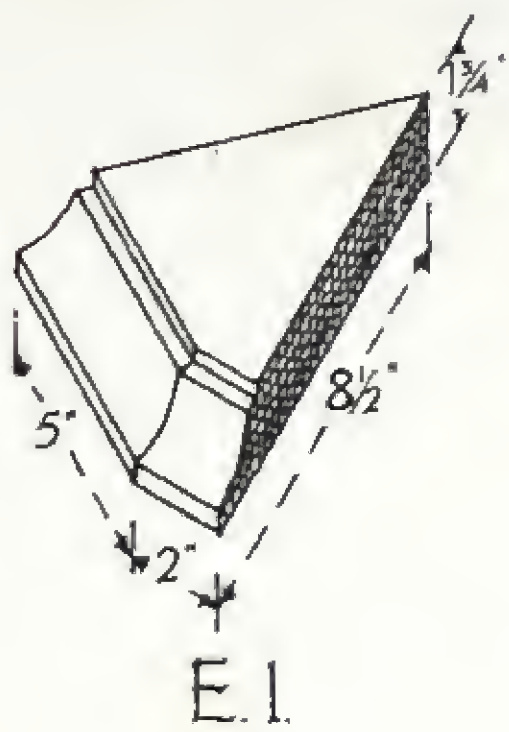
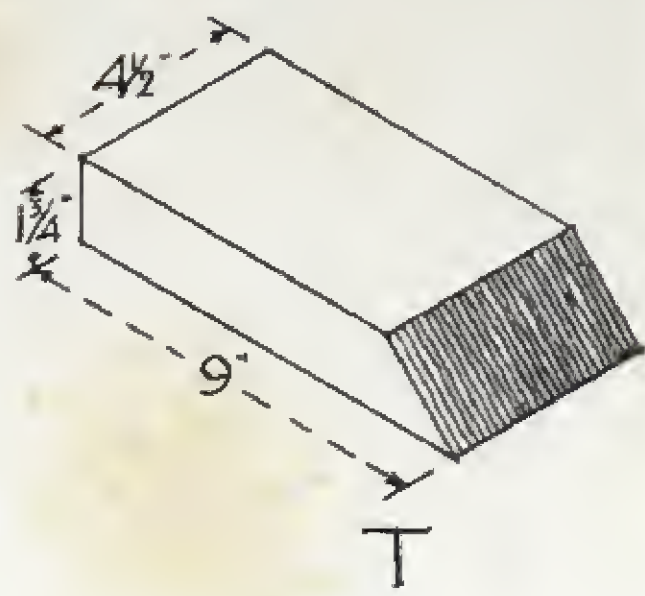

MULLION
BRICKS

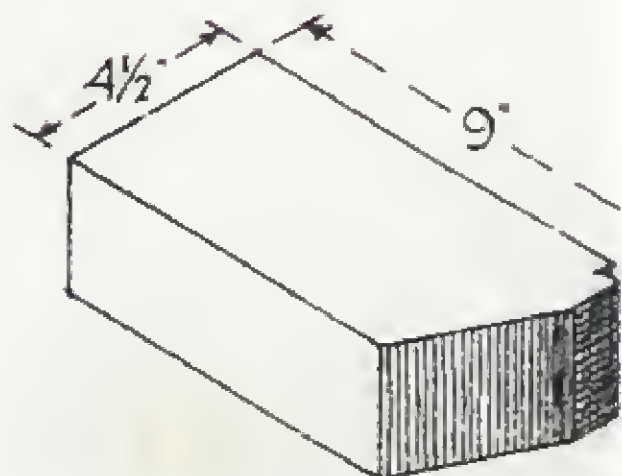

4

THE WESTHOWE FIRE

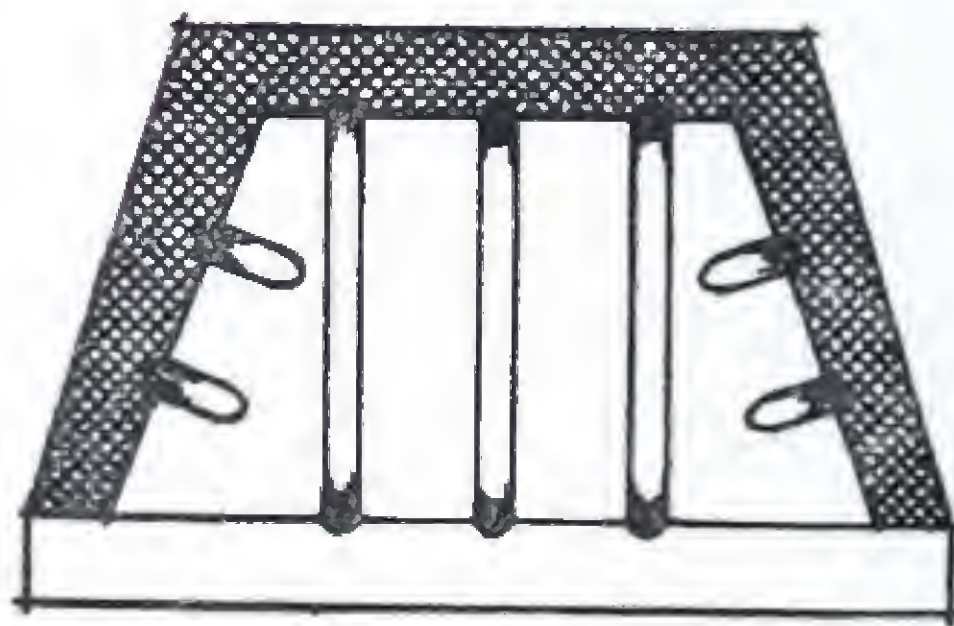

.Plan.

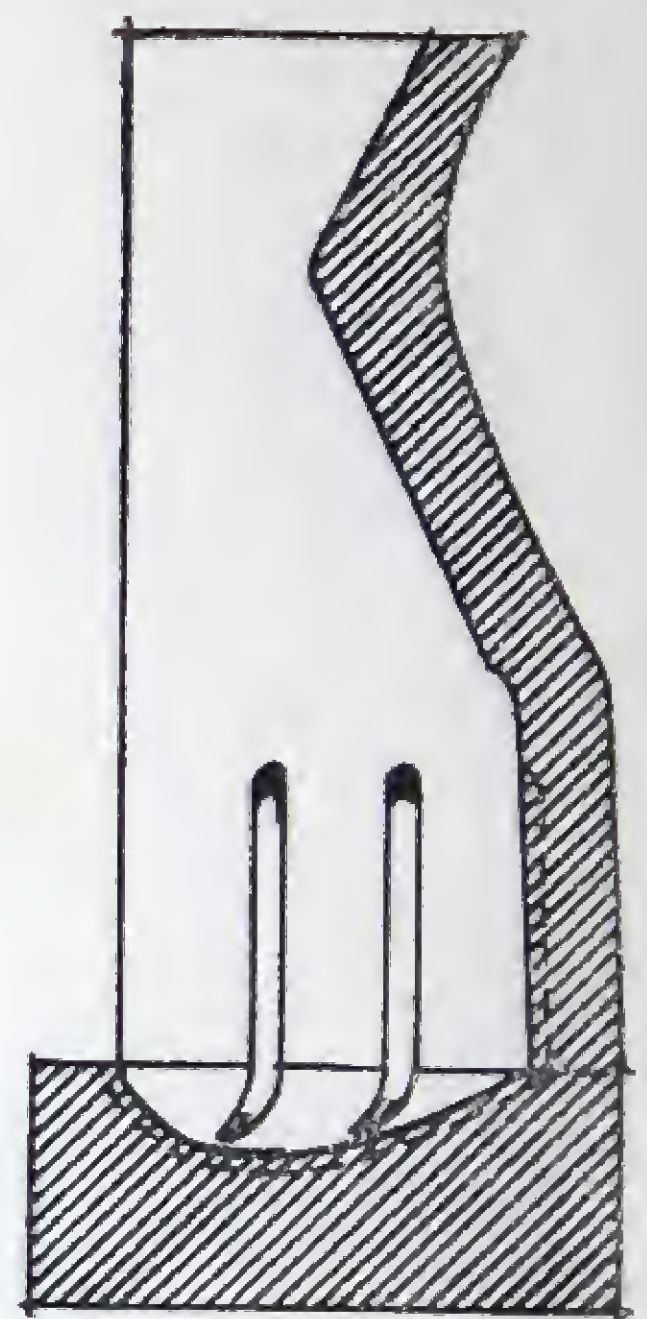

.Section.



.Scale of Feet.

THE WESTHOWE FIRE

ICKS

After receiving many requests from our Brick Fireplace clients, we have now designed a fire which is particularly suited for use in conjunction with Brick Fireplaces or any type of surround.

The Westhowe Fire is made in two pieces, as shown in the accompanying diagram.

The combination of the angles of the fire back and bottom were arrived at after considerable experiment and ensure perfect combustion and maximum heating powers.

The bottom is so designed to give exceptionally small fuel expenditure and at the same time the flutes in the bottom give sufficient draught to maintain a clear and steady fire.

One of the important features in the Westhowe Fire is that the well falls sharply in the front and rises gradually at the back, thereby eliminating the accumulation of dead ashes which so often gather at the rear of "Well Pattern" Fires, also, this sloping back to the well tends to throw the heat into the room.

These fire backs are made of carefully selected clays, combined with other ingredients, resulting in an exceptionally heat-resisting article.

Another good point is the simplicity of erection; the fire being made in only two pieces the fixing becomes a fool-proof operation.

The Westhowe Fire is made in the following sizes:— 21in., 18in., 16in. and 14in. Larger or smaller sizes can be made to order.

The prices of the above are as follows:— 21in. at 35/-; 18in. at 30/-; 16in. at 28/-; 14in. at 25/-, at our works. These prices are subject to variation without notice.

, LTD.

DIAGRAM

ELLIOTT'S WEST

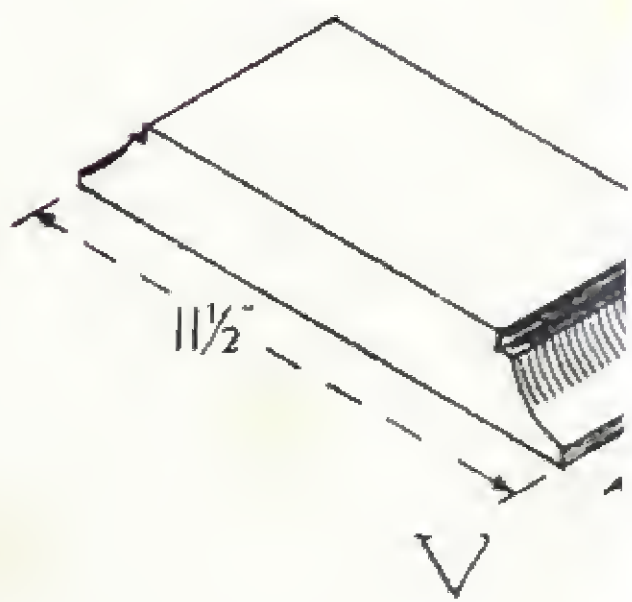
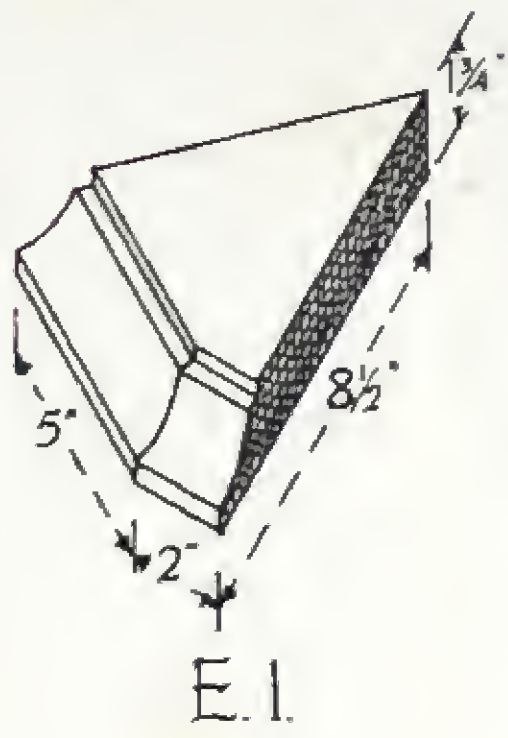
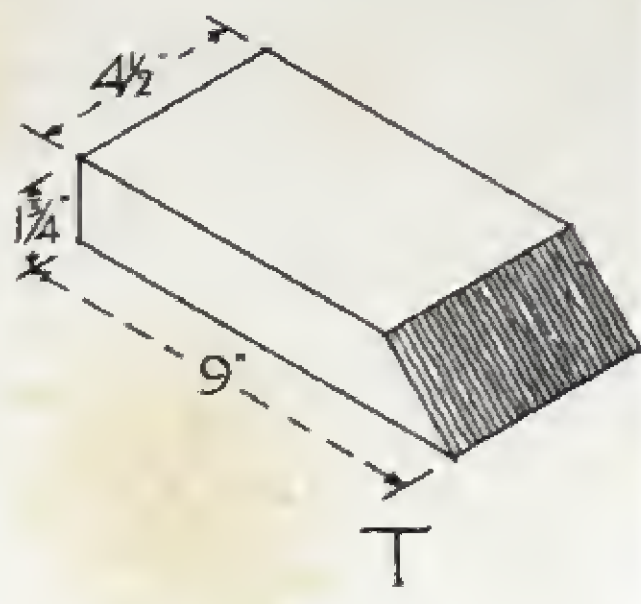

MULLION
BRICKS

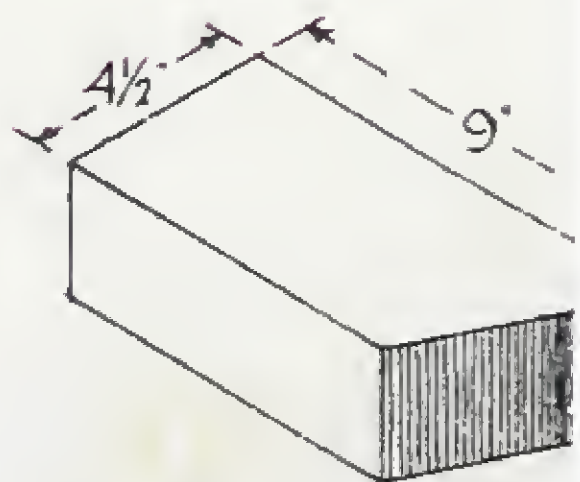

4

This Sheet is Copyright and the rights are strictly reserved.

DIAGRAMS OF
SANDFACED ANTIQUE BRICKS
AND SPECIALS

for

BRICK FIREPLACES

ETC.

Manufactured by the Antique Section of
ELLIOTT'S WEST HOWE POTTERY (DORSET), LTD.
KINSON,
NR. BOURNEMOUTH

DIAGRAMS OF ELLIOTT'S SMALL ANTIQUE BRICKS

Made by the ANTIQUE SECTION of
ELLIOTT'S WEST HOWE POTTERY (DORSET), LTD., KINSON, NR. BOURNEMOUTH

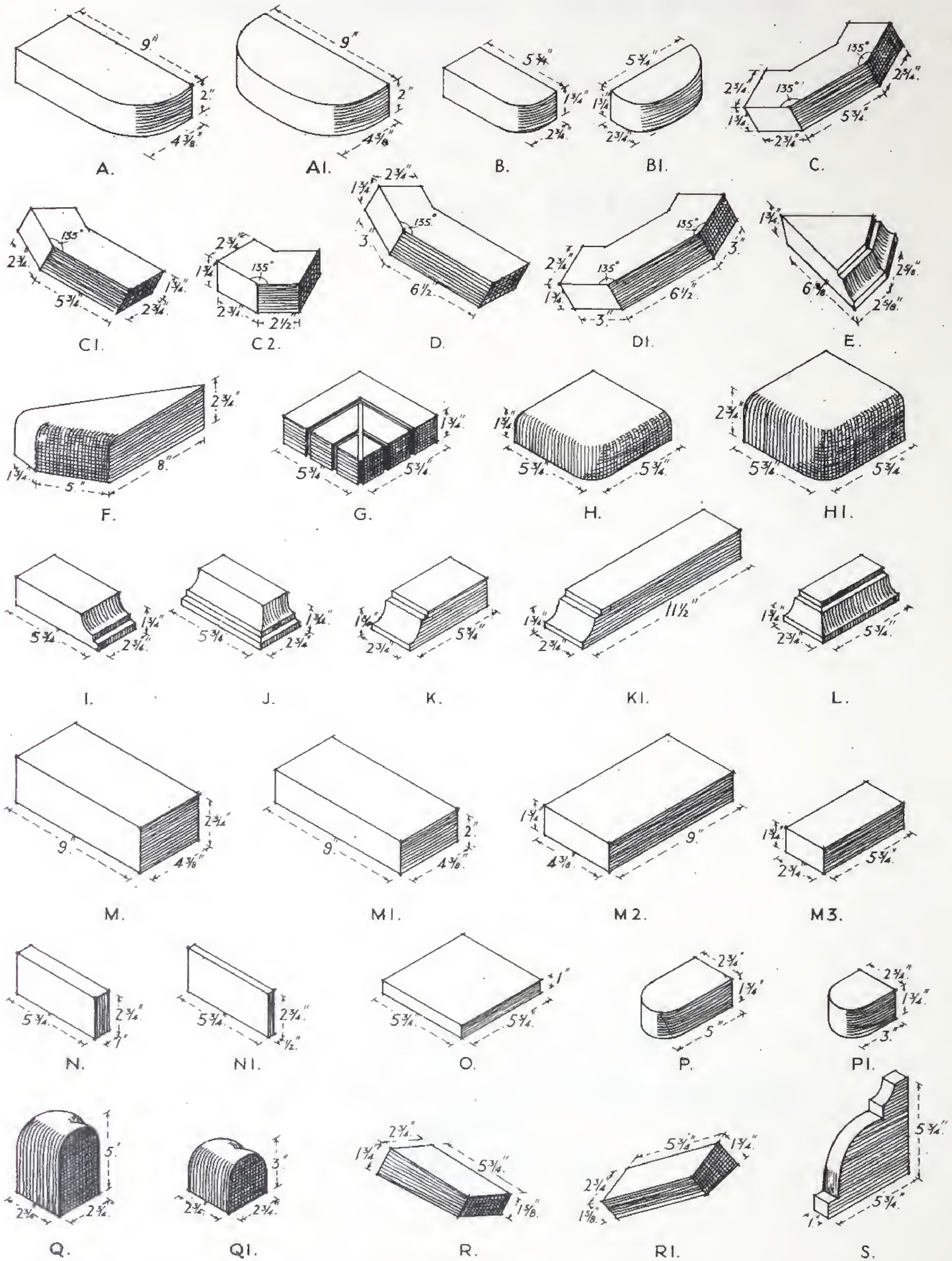

This Sheet is Copyright and the rights are strictly reserved.

NAMES OF THE FOREGOING DIAGRAMS

<p>A Single bullnose, $9'' \times 2'' \times 4\frac{3}{8}''$ A1 Double Bullnose, $9'' \times 2'' \times 4\frac{3}{8}''$ B Single Bullnose, $5\frac{3}{4}'' \times 1\frac{3}{4}'' \times 2\frac{3}{4}''$ B1 Double Bullnose, $5\frac{3}{4}'' \times 1\frac{3}{4}'' \times 2\frac{3}{4}''$ C Full octagon brick, small C1 $\frac{3}{4}$ octagon brick, small C2 $\frac{1}{2}$ octagon brick, small D $\frac{3}{4}$ octagon brick, large D1 Full octagon brick, large E Moulded return for octagon brick F Bullnose return for octagon brick G Ribbed hob brick H Hob bullnose brick, small H1 Hob Bullnose brick, large I Short moulded brick J Short moulded return K Short moulded brick K1 Long moulded brick</p>	<p>L Short moulded return M Large antique brick, $9'' \times 4\frac{3}{8}'' \times 2\frac{3}{4}''$ M1 Medium antique brick, $9'' \times 4\frac{3}{8}'' \times 2''$ M2 Small antique brick, long, $9'' \times 4\frac{3}{8}'' \times 1\frac{3}{4}''$ M3 Small antique brick, short, $5\frac{3}{4}'' \times 1\frac{3}{4}'' \times 2\frac{3}{4}''$ N Roman tile slip, $5\frac{3}{4}'' \times 2\frac{3}{4}'' \times 1''$ N1 Small tile slip, $5\frac{3}{4}'' \times 2\frac{3}{4}'' \times \frac{1}{2}''$ O Square hearth tile, $5\frac{3}{4}'' \times 5\frac{3}{4}'' \times 1''$ P Long curb brick, $5'' \times 2\frac{3}{4}'' \times 1\frac{3}{4}''$ P1 Short curb brick, $3'' \times 2\frac{3}{4}'' \times 1\frac{3}{4}''$ Q Long curb return Q1 Short curb return R Stretcher arch brick R1 Header arch brick S Special arch tile, moulded</p>
--	---

NOTES ON THE ABOVE

With a few exceptions the bricks shown on the opposite page explain themselves, but we think that a word is necessary in the following cases:—

C Full octagon brick, small: Four bricks to the complete octagon. This brick was originally designed to build up the side columns of fireplaces as in sketches Nos. 5, 7, 13, of our catalogue; a larger octagon brick is made which can be used as a cap to these columns, and has an overhang of 1" over the "small octagon brick" (see **D1**).

E and **F** are moulded caps for the octagon bricks with the required angle of 135° .

C1 and **D** are to be used to increase the diameter of the octagon to any required size, and for other uses which suggest themselves. As one can imagine, these octagon bricks have a multitude of uses. Some that are immediately apparent are: Encasing steel columns or stanchions, gateposts, chimneys (sketch No. 19), pergola columns (sketch No. 18), verandah columns, sundials, etc., etc. Their overall dimension is 14".

G. Ribbed hob brick. This brick can be used in many ways as shown in sketches Nos. 10, 11 of our catalogue. The grooves are $\frac{3}{8}''$ wide and $\frac{3}{8}''$ deep, and when pointed with mortar give the impression of separate pieces of brick, but being actually in one piece are very strong and require little labour to lay.

K1. Moulded brick, long. These bricks being $11\frac{1}{2}''$ long are very useful for top of mantel shelves, giving a good even mantel top.

QUOTATIONS GIVEN ON REQUEST



In an old world garden the above Sundial will create that longed for atmosphere of the dignity and charm of past ages.

Price complete with Antique Brass Sundial Plate £6 15s. od.

This design is copyright

NAMES OF THE FOREGOING DIAGRAMS

T	Special herringbone brick	S1	Internal angle return for S tile
N3	Long Roman tile, 9" × 4½" × 1"	S2	External angle return for S tile
M4	Hearth brick	V	Special 2" double moulded coping brick
U	1" bullnose brick	W	V-shaped coping brick
E1	Large moulded return for octagon brick	X	½ octagonal coping brick
L1	Moulded return, large	Y	Special string course brick

MULLION BRICKS

1	Mullion return	4	Stretcher jamb
2	Mullion brick	5	Header jamb
3	Jamb return	6	Head and sill brick

NOTES ON THE ABOVE

This second list is published in the hope that, like its predecessor, it will be useful to all brick users.

Since publishing the first list we have found that other bricks could be made to help greatly both the designer and the bricklayer.

We have placed first on this list our special herringbone brick **T**. Its size is 9" × 4½" × 1¾". One end is specially moulded to form an angle of 45°, thus greatly facilitating the laying of herringbone brickwork.

This brick does away with all the usual labour of cutting and rubbing the angles, with the accompanying high expense. Also, these specially moulded bricks result in much better work.

This brick is particularly useful for brick paving in garden and other work.

N3, **M4** and **U** explain themselves.

E1 is an improvement on **E** shown on our previous list, as it breaks the bond in capping octagonal work.

Again, **L1** is an improvement on **L**, which is also shown on our first list. This brick is the return angle brick for **K** and **K1**, giving a much better seating than did the smaller brick. **L1** can also be used for either hand.

Bricks **S1** and **S2** are the angle returns for our **S** tile, as these bricks obviate the mitreing of the **S** tile they effect a great saving in labour and expense.

The mullion bricks, again, explain themselves.

We will be pleased to give you any further information on our products, all of which are unconditionally guaranteed to give satisfaction.

QUOTATIONS GIVEN ON REQUEST